

XE-N SERIES

ELECTRIC SELF-PROPELLED SCISSOR LIFT

Mantall®
AERIAL WORK PLATFORMS

Standard Features

- XE-N series working height is 6.5m(about 21 feet and 8m (about 26 feet).
- The platform can outreach 0.9m (about 3 feet), and the machine can be 2.52m (about 8.26 feet)
- Compact design, can be easily passed single standard door and enter the lift, and so on.
- The min. lift capacity is 230kg(about 506 pound),the max. lift capacity is 270kg(594 pound).
- Proportional controls for lift and drive functions.
- Automatic 25 Amp battery charger provides strong power for vehicle.
- Safe distance protection when the platform lowering down.(CE)
- Manual Emergency platform lowering valve, when there is no power, the machine can be safety lower down.
- Emergency stop at both platform and ground controls.
- Drive speed interlock limits speed while elevated.
- Multiple disc brakes provide smooth deceleration.
- When there is no power, manual brake release function can move the machines under the circumstances when there is no other forklift, lifting equipment and so on.
- Pothole guards protect the machine don't tilting down when the machine moved on the raised position.
- Non-marking tires make sure there is no damage and no marks on the ground.
- It has the 30% gradeability, and at the same time each machine equipped tilt sensor alarm to make sure the user can use the machine correctly.
- Diagnostic system.



美通让工作更轻松!

免费咨询电话:4006178066

XE-N SERIES

Models	XE65N	XE80N
Working height max (m)	6.5	7.8
Platform height max (m)	4.5	5.8
(2)Outreach (m)	0.9	0.9
Lifting capacity (kg)	270	230
Lifting capacity (kg) (Extended platform)	115	115
Weight (kg) ANSI/CSA Standard	1164	1225
CE/AUS Standard	1235	1490
Platform size(3) × (5) × (6)(L × W × H)m	1.64 × 0.75 × 1.1	
(4)The length of platform extended (m)	2.54	
(7)Skirting board height (m)	0.15	
Stowed size(8) × (9)(L × W)m	1.85 × 0.77	
(10)Stowed height (m)	1.68fixed platform2.08CE	1.96fixed platform2.13CE
(13)Length of the machine with platform extended (m)	2.75	
(11)Width of the machine with platform folded (m)	1.69	1.78
Hydraulic tank capacity (L)	15	
Gradeability	25%	
(12)Wheelbase (m)	1.32	
Ground clearance (m)	0.06	
Pothole protection board ground clearance (m) (down)	0.02	
Inside rotation radius (m)	0	
Outside turning radius (m)	1.56	
Load number max	2	
Raised time/Lowering time (s)	16/22	16/23
Traction speed (km/h)	3.8	
Safe speed (km/h)	0.7	
Vertical tilt° ANSI CSA	3	3
CE/AUS	2	2
Lateral tilt° ANSI CSA	2	2
CE/AUS	1.5	1.5
Power source	4 × 6V; 225Ah	
Tire size (mm)	356 × 114 × 254	
Drive model	Hydraulic drive /electric drive	

XE-N Working Range

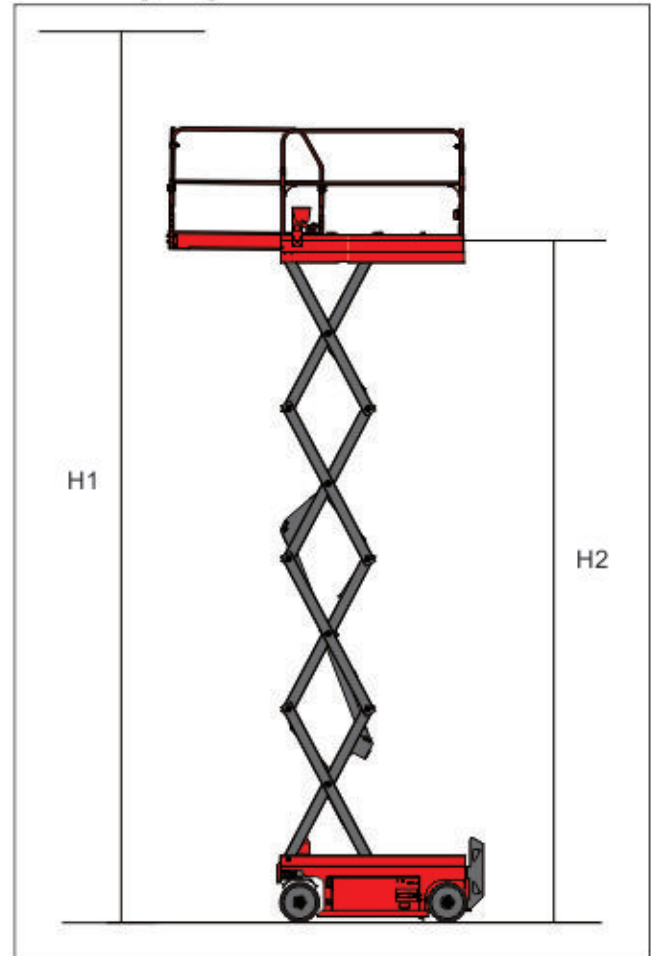

XE-N Collecting Chart

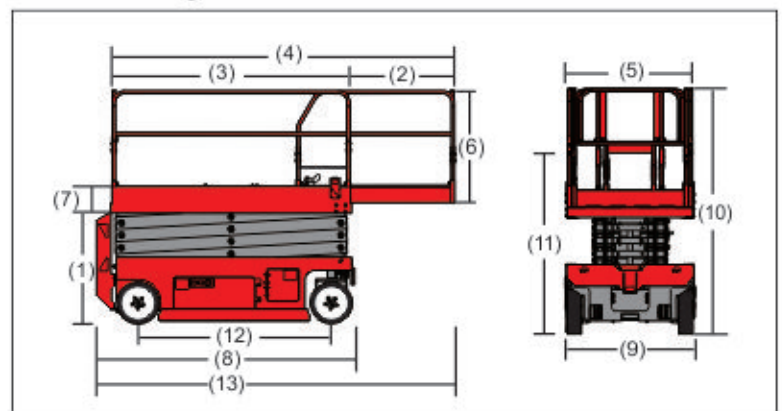

*The metric system height is 2 meters higher than platform height, the imperial height is 6 feet than platform height

**In the rising mode, the machine is designed to operate on a solid flat surface.

***Climbing ability is suitable for driving on the slope, the slope classification reference operation manual

****Weight according to the options and standards vary from country to country